



# Mio

TUBULAR MOTOR  
FOR SHUTTERS



**CAME**

# Mio

**Came has lifted  
the curtain on  
the field of  
automatic roller  
shutter systems**

Came presents the innovative Mio series, the new generation of electromechanical tubular gearmotors for roller shutters for home and civil automation.



# Reason to choose Mio

## FRIENDLY SUN, SAFE PROTECTION.

Reliability, precision, simple installation:  
Mio deserves a place in the sun in the field of automations and blackout systems.  
The Mio series comprises 3 different models, designed and constructed for integration into various types of shutters depending on their size and weight.  
They are extremely versatile and can even be housed in very small shutter boxes

## SHUTTERS ALREADY INSTALLED? NO PROBLEM, THERE IS A MIO FOR EACH ONE.

The Mio gearmotors are easy to regulate and can be fitted onto any old or new shutter.  
They have a progressive screw adjusted mechanical endstop and a range of mechanical adapters and accessories for the assembly and to customise the shutter.  
Came submits each single product to very strict quality tests, to guarantee long-lasting, precise functions and compliance with all current legal requirements and European standards.

### FLEXIBILITY, ADAPTABILITY AND SIMPLE INSTALLATION

1. Crown
2. Pulley
3. Spring
4. Square safety insert
5. Winding tube
6. Telescopic cap
- 7a. Support
- 7b. Split pin
- 7c. Support with bearing

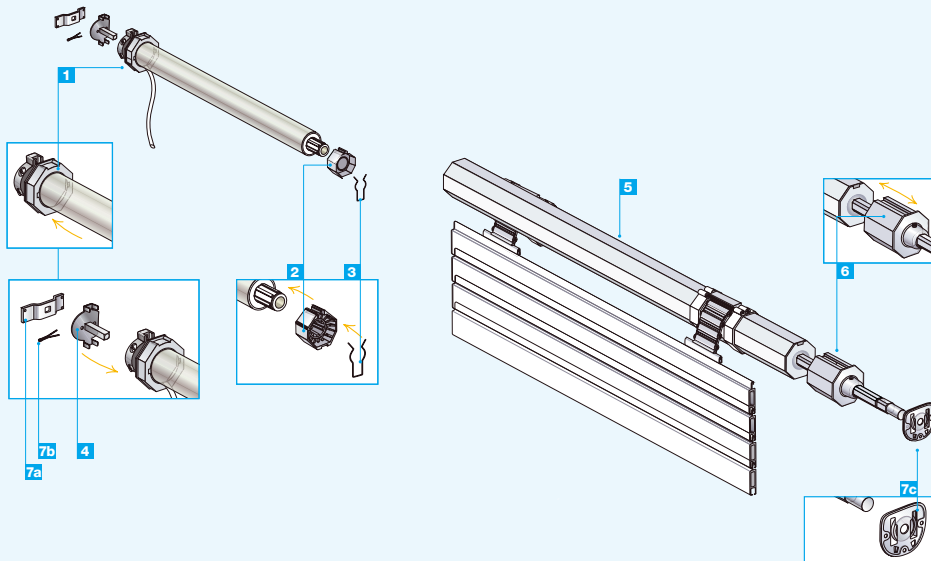

### Limit to use

MODEL	MI050S020	MI050S030	MI050S030
Torque (Nm)	20	30	40
Max lift capacity (Kg/lb)	36/79	55/121	74/163
HEIGHT OF BLINDS (m/ft)		up to 1,5/4.92	
Max lift capacity (Kg/lb)	36/79	55/121	74/163
HEIGHT OF BLINDS (m/ft)		from 1,5/4.92 to 2,5/8.20	
Max lift capacity (Kg/lb)	36/79	45/99	60/132

# The Mio range



## 230 V AC (50 Hz) gearmotors 50 series

001 <b>MI050S020</b>	Electromechanical tubular gearmotor (20 Nm) with progressive screw-adjusted endpoints (lift capacity = max 36 Kg / 79 lb).
001 <b>MI050S030</b>	Electromechanical tubular gearmotor (30 Nm) with progressive screw-adjusted endpoints (lift capacity = max 55 Kg / 121 lb).
001 <b>MI050S040</b>	Electromechanical tubular gearmotor (40 Nm) with progressive screw-adjusted endpoints (lift capacity = max 74 Kg / 163 lb).

## Accessories

001 <b>AMTAP0924</b>	Adaptor kit for 50 series tubular gearmotors for 59 mm / 2.32 in octagonal tubes.
001 <b>AMTAP0912</b>	Adaptor kit for 50 series tubular gearmotors for octagonal tubes of min 70 mm and max 71.5 mm / min 2.75 in and max 2.81 in.
001 <b>AMTAP0916</b>	Adaptor kit for octagonal tubes of 60 mm / 2.36 in.
001 <b>AMTAM0553</b>	Support with 48 mm / 1.89 in distance between holes for 50 series tubular gearmotors.
001 <b>AMTAM0523</b>	Screw support for 50 series tubular gearmotors.
001 <b>AMTAM0663</b>	ST bearing wood holder.
001 <b>AMTAM0655</b>	Ø 28 mm / 1.10 in bearing holder.
001 <b>AMTAM0511</b>	Standard support.
001 <b>AMTAM0947</b>	Ø 60 mm / 2.36 in octagonal shell (with Ø 12 mm / 0.47 in pin).
001 <b>AMTAM0673</b>	Adjustable ST bearing holder.
001 <b>AMTAM0670</b>	ST ball bearing.
001 <b>AMTAM0674</b>	ST bearing.
001 <b>AMTAM0656</b>	Ø 28 mm / 1.10 in metal bearing with Ø 12 mm / 0.47 in hole.
001 <b>AMT11653NY</b>	Squared safety insert for 50 series tubular gearmotors.
001 <b>AMTAM0652</b>	Ø 60 mm / 2.36 in octagonal telescopic shell (with Ø 12 mm / 0.47 in pin).
001 <b>AMTAM0653</b>	Ø 70 mm / 2.75 in octagonal telescopic shell (with Ø 12 mm / 0.47 in pin).

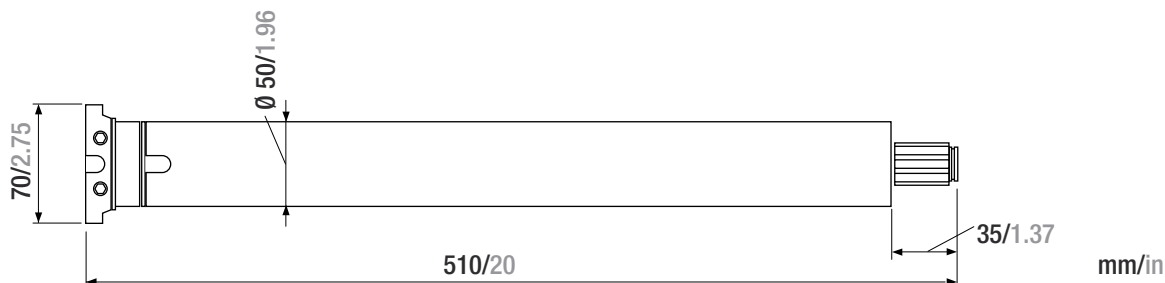

## Technical features

Type	MI050S020	MI050S030	MI050S040
Protection rating IP	IP44	IP44	IP44
Power supply (V - 50/60 Hz)	230 AC	230 AC	230 AC
Operator weight (Kg)	2,2	2,7	2,8
Current draw (A)	0,57	0,73	0,98
Power (W)	129	168	226
Rotation speed (rpm)	13	13	13
Working time (min)	4	4	4
Torque (Nm)	20	30	40
Operating temperature (°C/°F)	-10 ÷ +50/+14 ÷ +122	-10 ÷ +50/+14 ÷ +122	-10 ÷ +50/+14 ÷ +122
Motor thermo protection (°C/°F)	160/320	160/320	160/320

● 230 V AC

**FIND OUT WHAT'S  
NEW WITH CAME**  
from your wholesaler  
or from [came.com](http://came.com)



PRODUCTS



**Came cancelli automatici s.p.a.**

Via Martiri della Libertà, 15  
31030 Dosson di Casier  
Treviso - Italy  
Tel. (+39) 0422 4940  
Fax (+39) 0422 4941  
info@came.it  
www.came.com

